

Towards a seamless cloud fraction scheme for Unified Physics

Paul Barrett, Frankie Cottrell, Mike Whittall, Cyril Morcrette

Seamless Modelling Workshop

Bristol, June 2025

Cloud Fraction Schemes

Cloud formation

Clouds form when local water vapour content is above saturation

Then $wv = q_{sat}$ and surplus becomes liquid water content (q_{cl}).

Now consider a region:

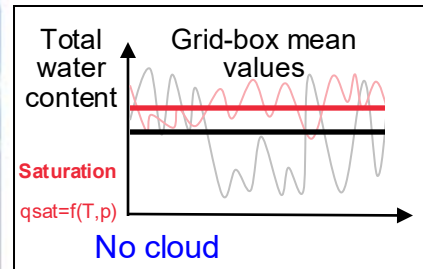
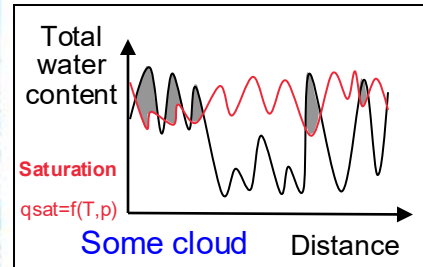
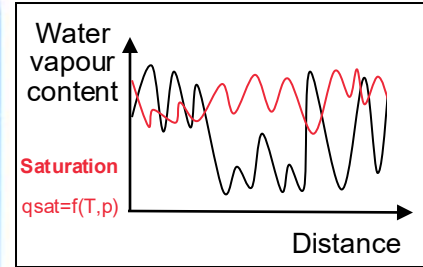
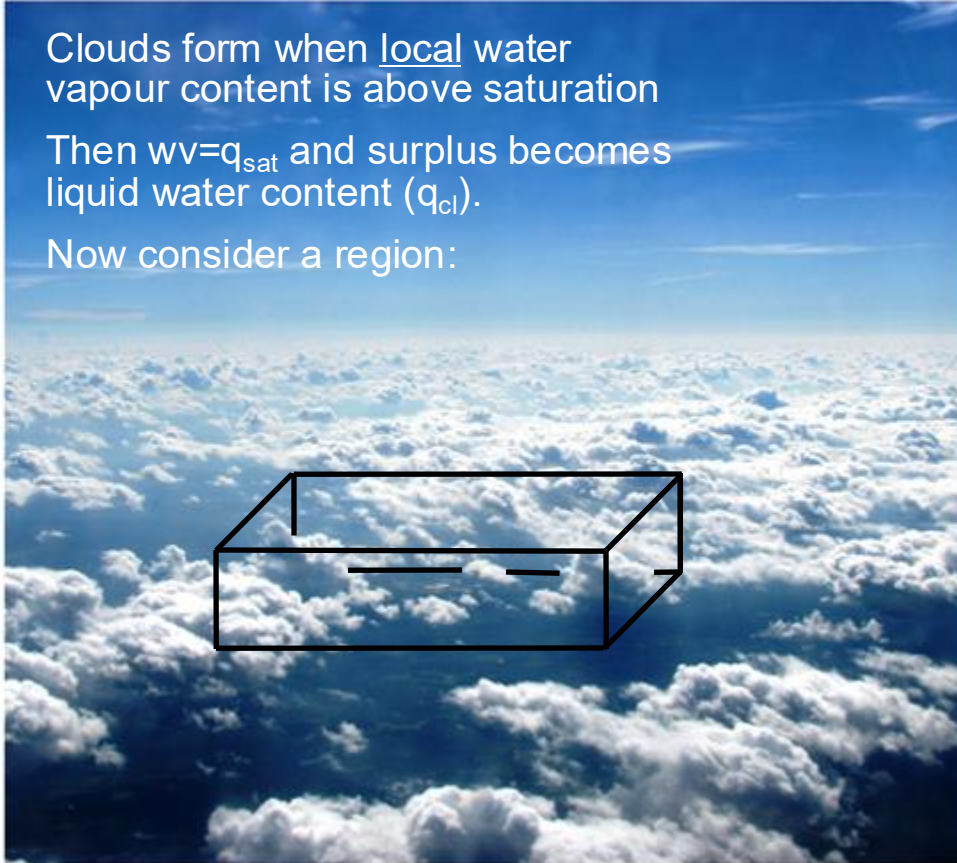

A Simple Cloud Scheme

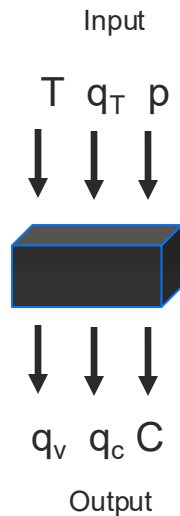

A very simple cloud fraction scheme.

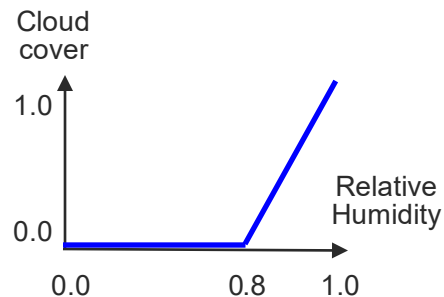

Diagnostic scheme in Unified Model has more complexity, but ultimately for a given atmospheric state (T, q, p) there is only one possible value of cloud cover and liquid water content.

Prognostic vs diagnostic approaches

Diagnostic: Infers cloud water content and cloud fraction from the large-scale state at each timestep. There is **no** memory of what the cloud properties were in any prior timestep.

Prognostic: Specifies a time dependent equation to calculate increments to the cloud water content and cloud fraction from all processes that change temperature and/or specific humidity.

$$\frac{\partial \overline{q_{cl}}}{\partial t} = \frac{\partial \overline{q_{cl}}}{\partial t} |_{advection} + \frac{\partial \overline{q_{cl}}}{\partial t} |_{convection} + \frac{\partial \overline{q_{cl}}}{\partial t} |_{boundary\ layer} + \frac{\partial \overline{q_{cl}}}{\partial t} |_{precipitation} + \dots$$

Clouds are advected through the model and there **is** memory of properties at previous timesteps.

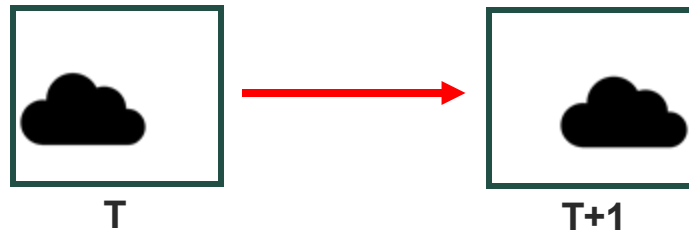

Cloud Macrophysics Schemes

1990

Smith - diagnostic
No 'memory' of cloud fraction, only focusses on current state

2002

PC2 - prognostic
Has 'memory' of cloud fraction as it considers evolution over time

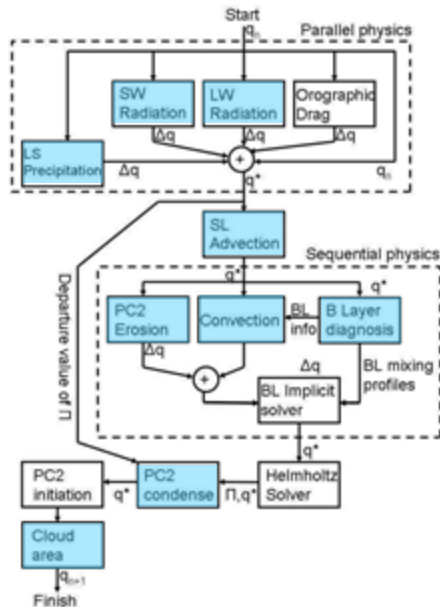

2020

Bi-Modal – diagnostic
Like Smith scheme but accounts for two modes of variability.

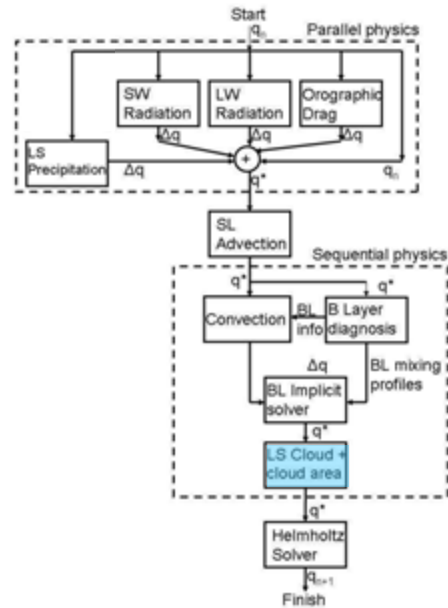

now

Hybrid
PC2 for ice (prognostic)
Bi-Modal for liquid (diagnostic)

PC2+
PC2 for ice (prognostic)
PC2 for ice with Bi-Modal initiation for liquid (prognostic)

Descriptions of Cloud Fraction Schemes

Smith Scheme

- Original UM
- Diagnostic: Assumes supersaturation is instant (OK for liquid, not for ice) – no memory
- Assumes triangular subgrid saturation PDF - fixed width,
- linked to profile of critical relative humidity
- Problem is specifying the width of the PDF
- This is obtained from the variability of q and T in surrounding grid-boxes
- Fixed triangular shape is a problem – there should be some skewness

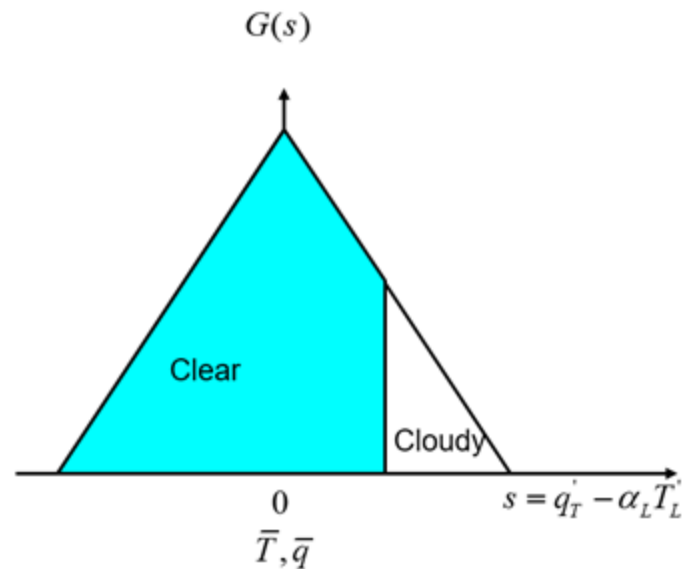

Smith + Empirical Adjustment to Observations

- **observations** suggest that at RH=100% the mean cloud cover is not $C=0.5$, but higher, more like $C=0.65$ or $C=0.7$
- This implies that the PDF of fluctuations is not symmetric after all.
- Hence desire to move away from Smith scheme with its uni-modal symmetric triangular PDF.
- Empirically Adjusted Cloud Fraction (EACF) to observations using: Wood & Field (JAS2000)

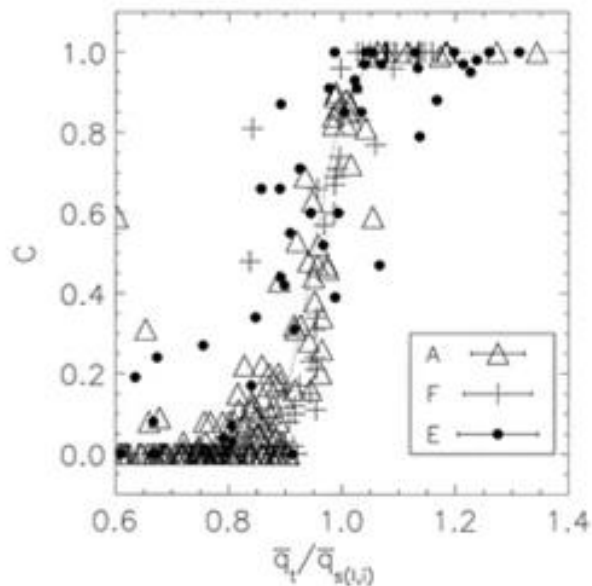

Bi-modal

- Allows for skewed humidity distributions
- Mixing in of air in entrainment zone
- More physically based
- Improved CF forecasts with need for empirical adjustment to observations
- Not perfect!

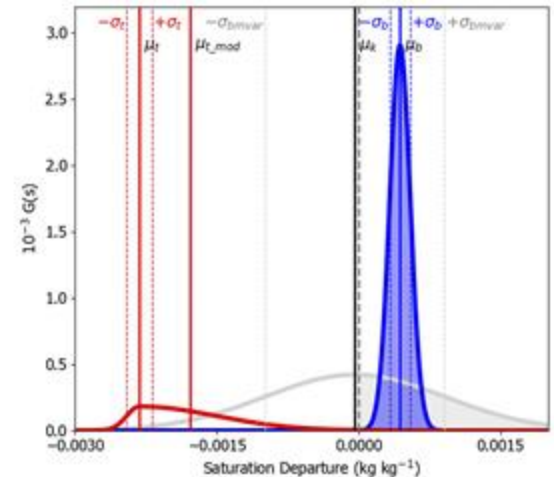
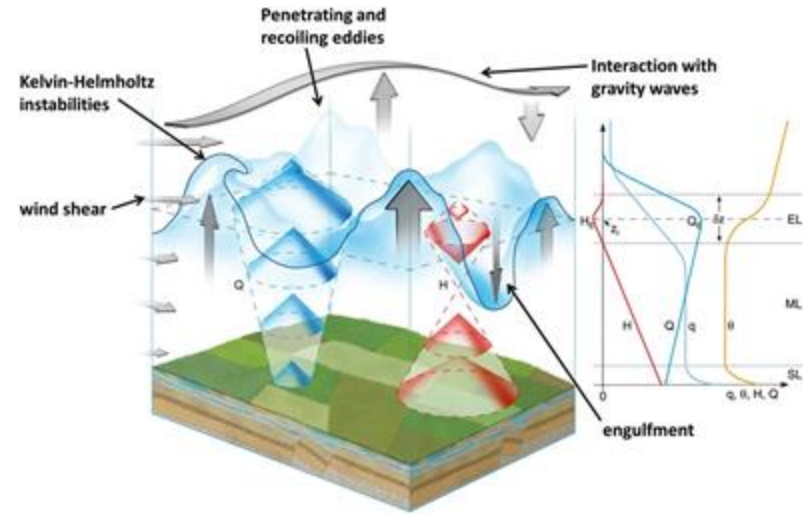

Bimodal CF Comparisons

		Cloud fraction at RH=100%	
Observed	90 %		
Smith	47 %		Original UM
Smith EACF	65 %		RA2M
BM	54 %		Better distribution of CF, liquid
BM – EZ	69 %		Entrainment zone

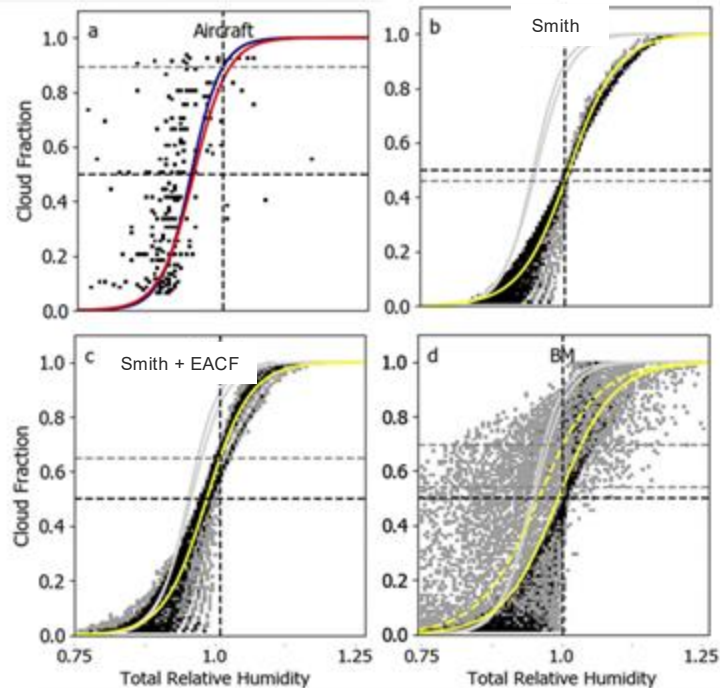

PC2 (Wilson 2008)

- Suppose we have some cloud...
- Some processes will create more
 - Convection, long-wave cooling
- Others will try to destroy it
 - Precipitation, short-wave heating
- As long as we know the PDF of the source and sink terms, we don't actually need to know the PDF of the original cloud
- Mean, variance and skewness all vary in a way consistent with the forcing

$$\frac{\partial C}{\partial t} = \frac{\partial}{\partial t} \int_{-Q_c}^{\infty} G(s) ds = G(-Q_c) \frac{\partial Q_c}{\partial t} + \int_{-Q_c}^{\infty} \frac{\partial G(s)}{\partial t} ds$$

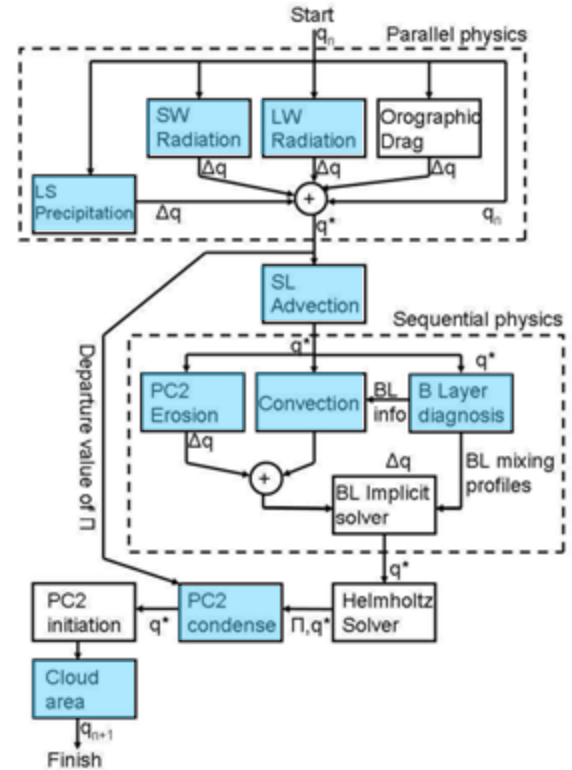

Cloud Schemes: What is used where

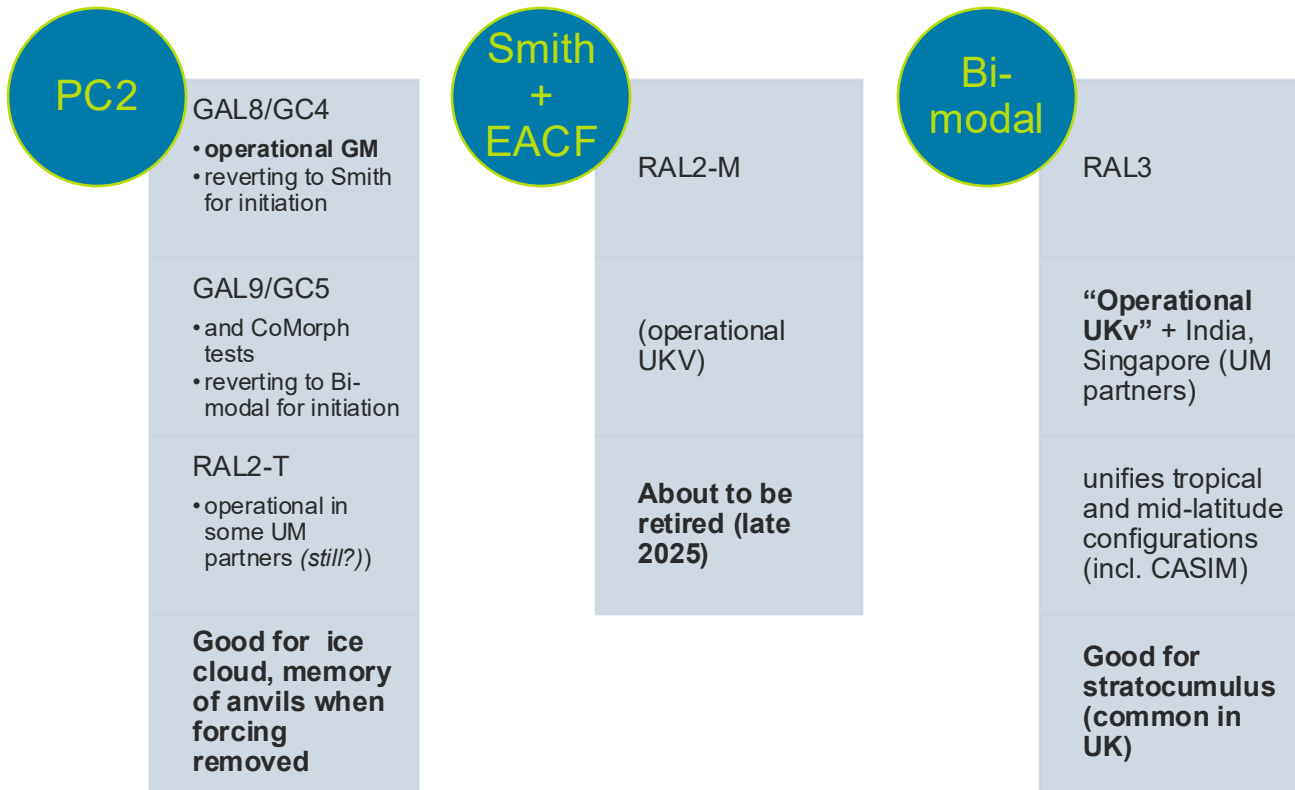

Unified Physics

Convection

6A
Separate schemes for deep, shallow and mid-level convection

CoMorph
Single parcel ascent / descent code for all plumes

Microphysics

Wilson & Ballard
Single moment

```

    graph TD
      V[VAPOUR] -- "Evaporation" --> R[RAIN]
      R -- "Fall in" --> V
      R -- "Fall out" --> V
      V -- "Condensation" --> L[LIQUID]
      L -- "Evaporation" --> V
      L -- "Bergeron Process" --> I[ICE]
      I -- "Nucleation" --> L
      I -- "Deposition/Sublimation" --> L
      I -- "Melting" --> R
      R -- "Capture" --> I
      I -- "Fall in" --> V
      I -- "Fall out" --> V
      L -- "Freezing" --> I
      I -- "Autoconversion/Accretion" --> V
  
```

CASIM*
Can have multiple moments

```

    graph TD
      WV[Water vapour, qv] -- "Evaporation" --> CW[Cloud water, qc, nc]
      CW -- "Condensation" --> WV
      CW -- "Freezing" --> CI[Cloud ice, qi, ni]
      CI -- "Deposition" --> CW
      CI -- "Sublimation" --> WV
      WV -- "Nucleation" --> CI
      CI -- "Melting" --> CW
      CW -- "Autoconversion" --> R[Rain, qr, nr]
      R -- "Collection" --> CW
      R -- "Fall out" --> WV
      CI -- "Autoconversion" --> S[Snow, qs, ns]
      S -- "Collection" --> CI
      S -- "Fall out" --> WV
      S -- "Melting" --> G[Graupel, qg, ng]
      G -- "Collection" --> S
      G -- "Fall out" --> WV
  
```

Large-Scale Cloud

Smith
Diagnostic

Assumes triangular subgrid saturation-departure probability density function with a fixed width, linked to profile of critical relative humidity

PC2
Prognostic

Calculates increments to liquid and ice cloud fraction and condensate amounts that get advected by the resolved wind

Bi-Modal
Diagnostic

Like Smith scheme but accounts for coexistence of two modes of variability within a grid box near entrainment zones

A hybrid scheme
Prognostic/diagnostic

PC2 for ice, Bi-modal for liquid



Order of work

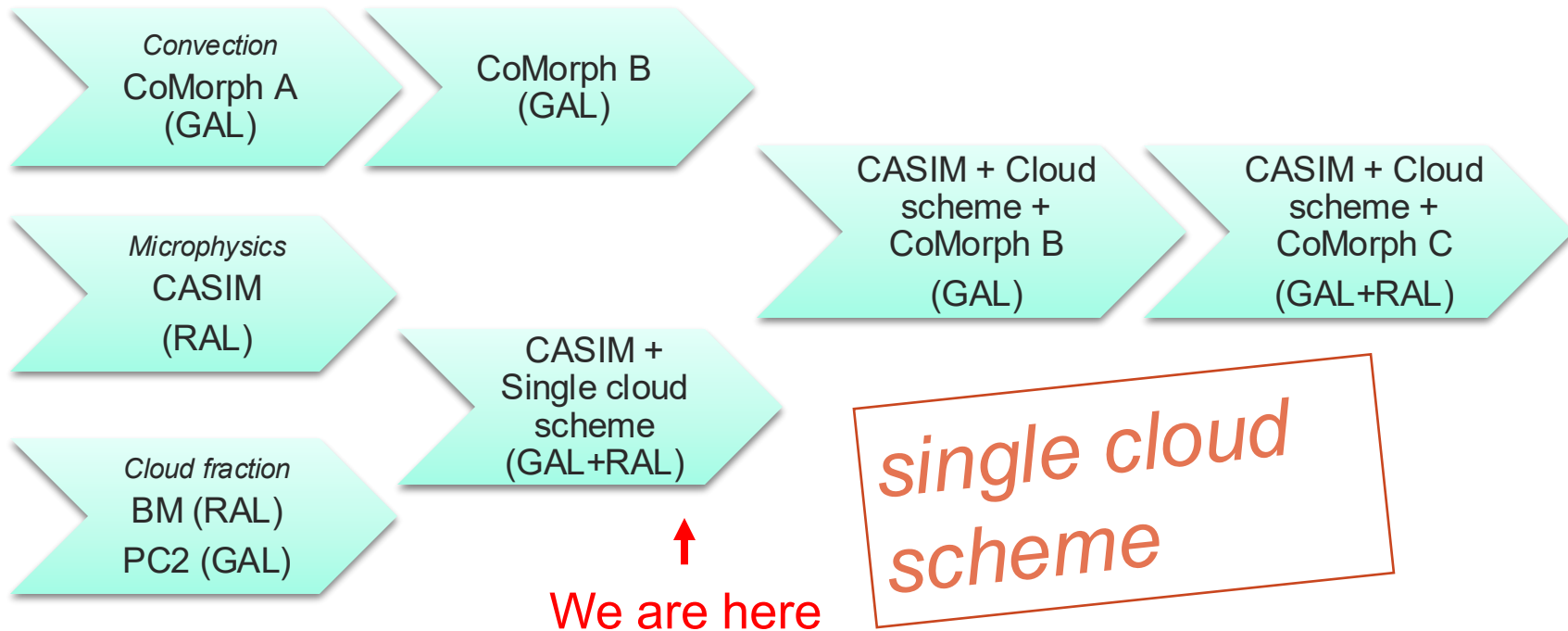

Large Cloud Scheme: Cloud Fraction

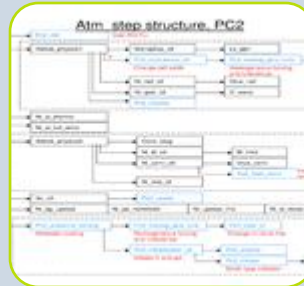
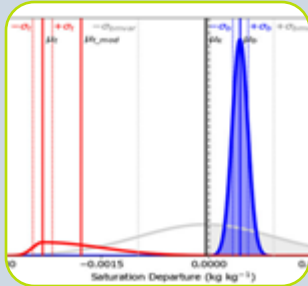
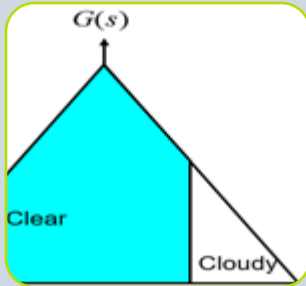

*In
Development*

*Unified Physics
Candidate*

*In
Development*

*Unified Physics
Candidate*

Smith Scheme

Original UM

- **Diagnostics**

- Assumes triangular subgrid saturation PDF - fixed width,
- linked to profile of critical relative humidity
- [Smith \(QJ1990\)](#)
- Empirical adjustment to obs using: [Wood & Field \(JAS2000\)](#)

Bi-modal

Operational
Regional

- **Diagnostics**

- Like Smith scheme
- but accounts for coexistence of two modes of variability within a grid box near entrainment zones
- [van Weverberg \(MWR 2021\)](#)

PC2

Operational Global

- **Prognostic**

- Calculates increments (from BL, conv, etc)
- to liquid and ice cloud fraction and condensate amounts
- Species advected by the resolved wind
- Bimodal used for liquid initiation
- [Wilson \(QJ2008\)](#)

PC2+

Unified Physics
Candidate

- **Prognostic**

- PC2 for ice,
- PC2 for liquid with Bi-modal initiation
- Many improvements + fixes
- Improved interactions with BL
- Designed to interface to CoMorph and CASIM

Hybrid

Unified Physics
Candidate

- **Prognostic** PC2 for ice,

- **Diagnostics** bimodal for liquid,
- Interfaced to CASIM

Cloud Scheme Investigation

- Previous studies have shown **no clear ‘winner’ for cloud fraction scheme** yet, since both prognostic and diagnostic approaches show disadvantages
- e.g. PC2 has been shown to be bad at simulating UK stratocumulus, and Bi-Modal performs poorly at climate scales due to a lack of memory (e.g. cirrus anvils)
- We’ve developed a framework for testing candidate cloud fraction schemes using **high resolution (300m)** runs
- This grid spacing was chosen as most deep convection is resolved so **no convection scheme is needed**
- Tests of **shallow cumulus** and **stratocumulus** in the **WesCon* domain** were run with several science configurations

Model Setup

- Ran **high resolution** Regional Nesting Suite (UM **vn13.0**)
- **South UK domain** (50.5°N – 53.5°N, 5.5°W – 1.5°E)
- Simulation length = **30 hours** (but first 6 hours will be model spin-up) starting at 12Z the day before
- Global resolution = n1280, first nested region resolution = 1.5km, second nested region resolution = **300m**
- Ran the following configurations:

Config.	Cloud Scheme	Microphysics Scheme
GAL9 (No Conv)**	PC2 (prognostic)	Wilson & Ballard (1M)
RAL3.2	Bi-Modal (diagnostic)	CASIM (2M)
RA2M	Smith (diagnostic)	Wilson & Ballard (1M)
RA2T	PC2 (prognostic)	Wilson & Ballard (1M)

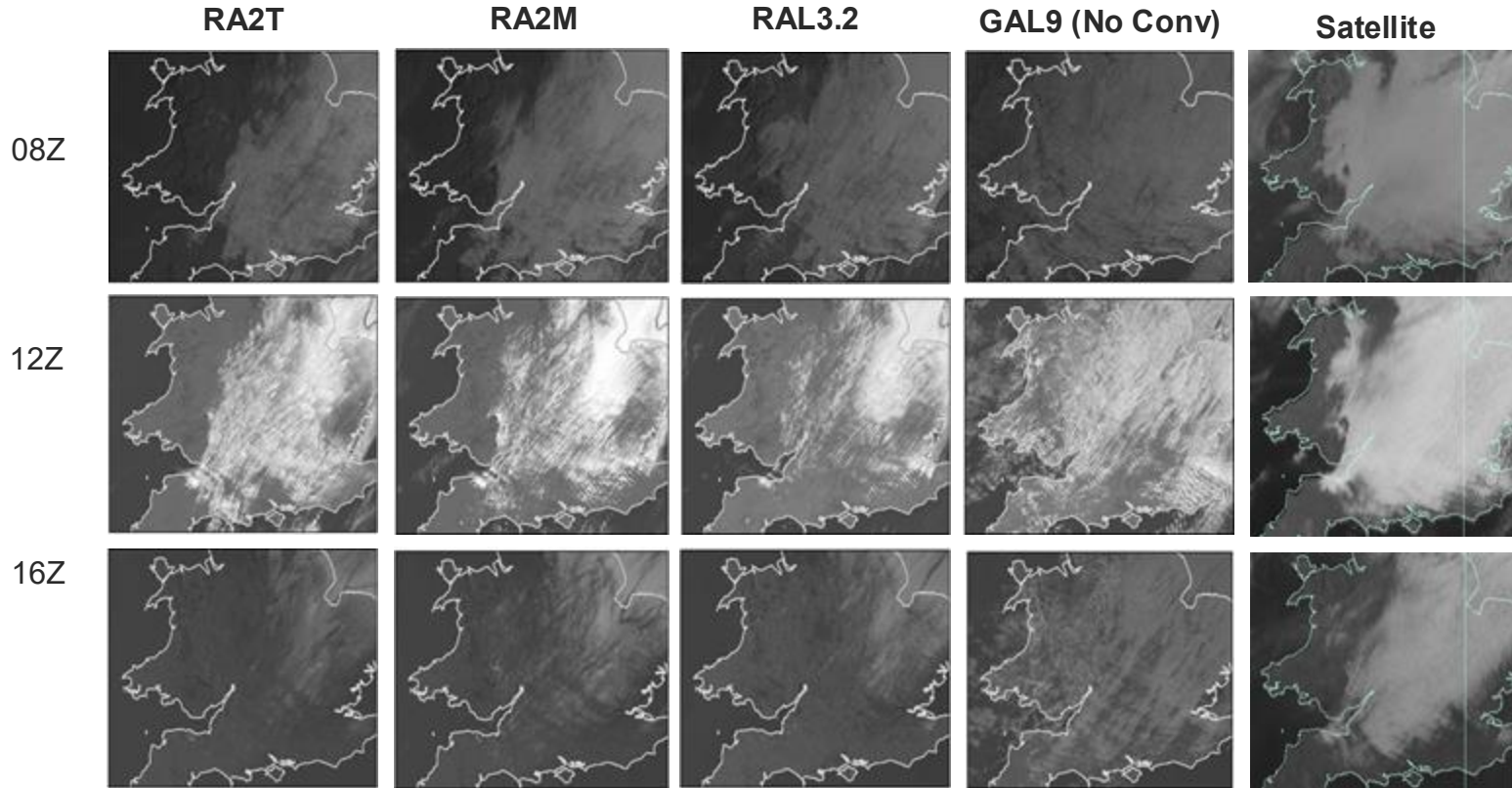

Next Steps

To simulate partial stratocumulus cover due to detrainment of cloud by parameterised convection at coarse resolution, we probably need a prognostic cloud scheme, since cloud-cover in dry grid-mean environments mainly depends on past history of convective detrainment.

If UP is going to generalise across scales, then it likely needs a prognostic cloud-scheme (even though it probably isn't needed at km-scale).

But existing regional model configurations use diagnostic cloud-scheme (bimodal in RAL3) and seem to depend on it for model performance (previous UK NWP tests using PC2 looked pretty bad...)

Options:

- a) Try to extend existing RA diagnostic bimodal cloud-scheme to include a prognostic variable fed by convective detrainment?
- b) Try and implement the existing PC2 prognostic cloud-scheme and improve it so it works better at km-scale?

Next: attempting option (b) – explore why PC2 performs badly in UK regional NWP and try to fix it!

Results

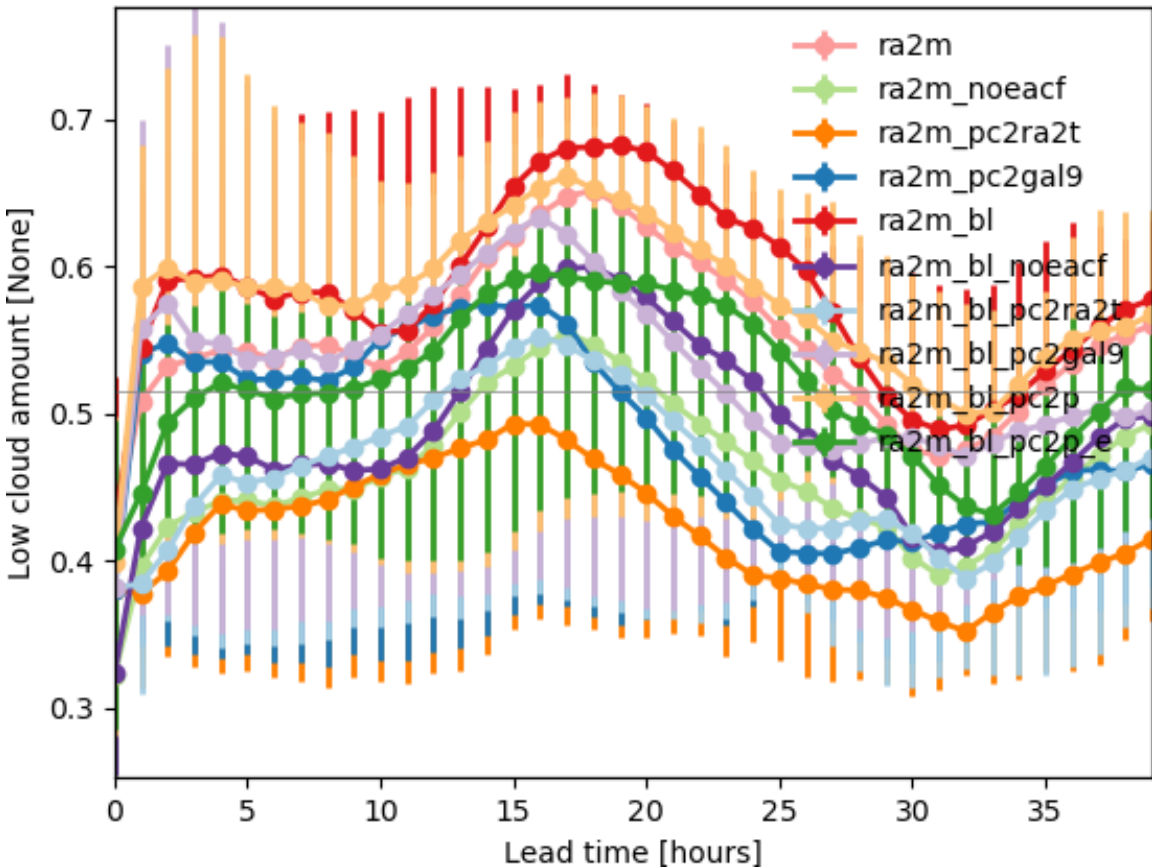

Low cloud amount averaged over UKV model-domain and 8 different forecast dates

RA2M (Smith)

RA2M (PC2)

Switching from **Smith** (fixed RHcrit) to the **PC2 setup used in RA2T** (initiation of condensation still uses Smith, but with TKE-based RHcrit) reproduces historically-seen detrimental large reduction in low-cloud cover.

Results

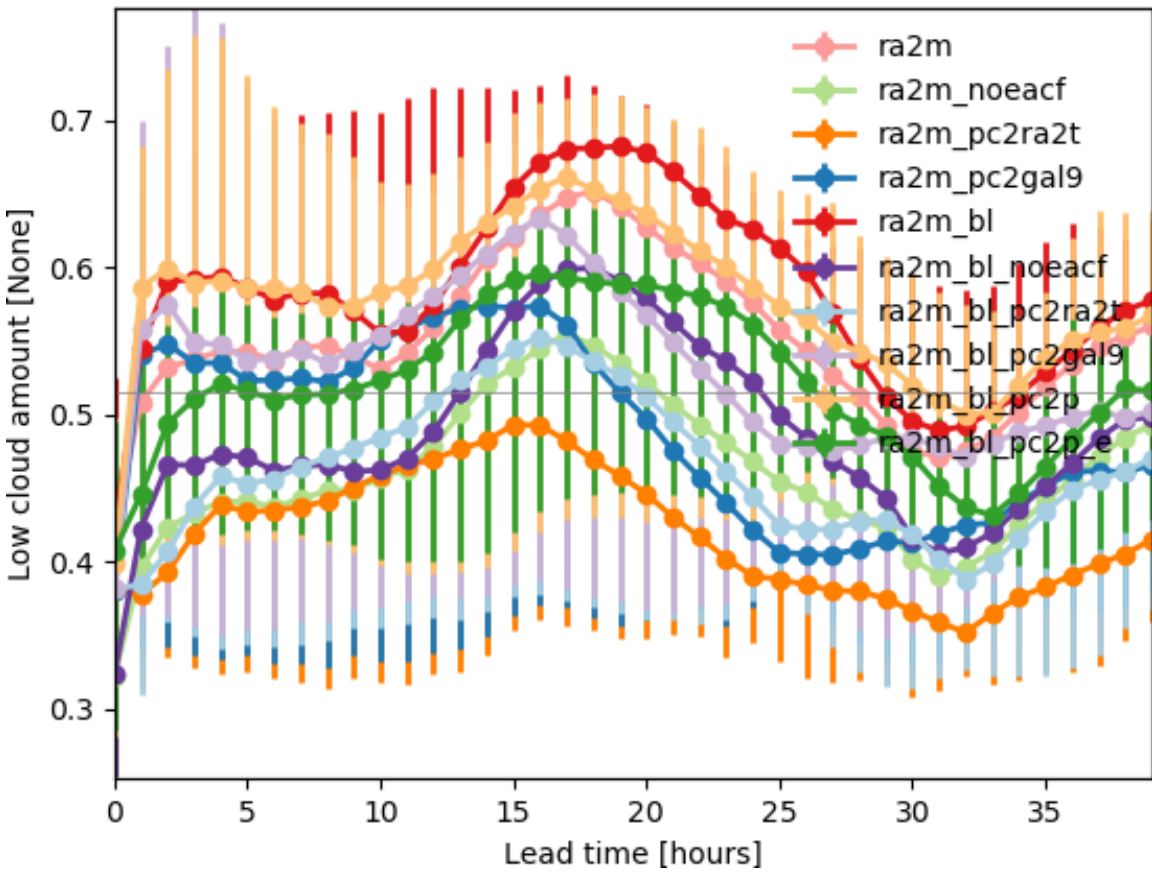

Low cloud amount averaged over UKV model-domain and 8 different forecast dates

RA2M (Smith)

RA2M (Smith) EACF off

RA2M (PC2) + BL(ComB)

RA2M (PC2)

How can we increase low-cloud again?

1) Numerical improvements to turbulent mixing in stratocumulus (part of the CoMorph B package). This gets us back to where we were with Smith (excluding EACF).

Results

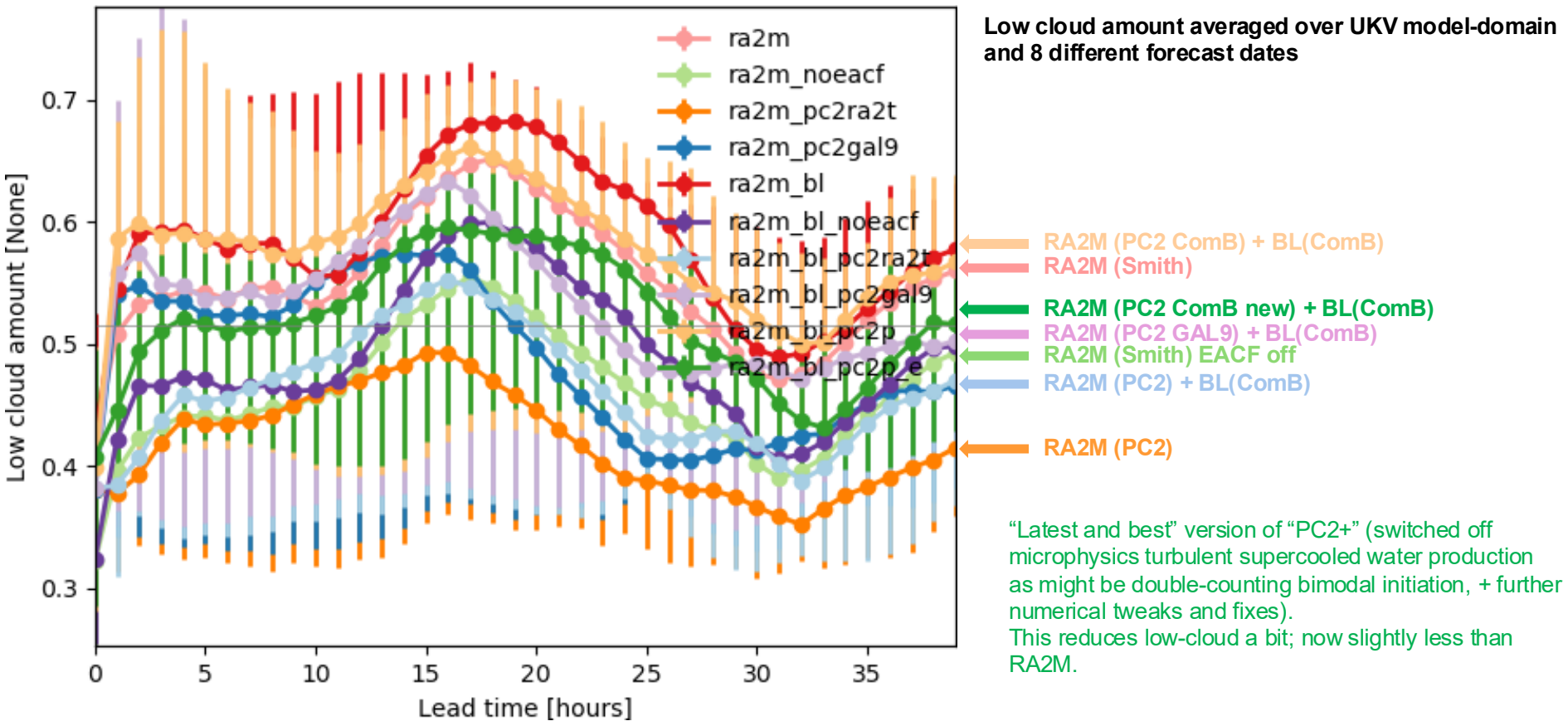

Results so far

- Can recreated porr PC2 performance in Sc
- Can get PC2 close to Smith with new fixes
- Ironed out many config discrepancies Global:regional
 - E.g. Turbulence components
- Identified more discrepancies to work on
 - E.g. treatment of erosion of clouds

Next Steps

- Two candidate cloud fraction schemes are being prepared: PC2+ and Hybrid
- PC2 for Ice – prognostic,
- Further high-resolution tests (without parameterised convection)
- Explore performance across regimes – UK stratocu + showers + frontal, Darwin tropical convection, Arctic cold-air-outbreak, New Mexico continental convection

*In
Development*

*Unified Physics
Candidate*

*In
Development*

*Unified Physics
Candidate*

PC2+

Unified Physics
Candidate

- **Prognostic**
- PC2 for ice,
- PC2 for liquid with Bi-modal initiation
- Many improvements + fixes
- Improved interactions with BL
- Designed to interface to CoMorph and CASIM

Hybrid

Unified Physics
Candidate

- **Prognostic** PC2 for ice,
- **Diagnostic** bimodal for liquid,
- Interfaced to CASIM
- Input of mode of variability from convection (CoMorph)

Problem: PC2 has never been *entirely* implemented in the regional model!

Alas! Alack!

Several bugs specifically exposed by switching on PC2 in LAMs ☹️ Links to tickets describing the bugs found so-far and attempts to fix them:

Purple
Orange

= fixed in the tests shown here.
= fix not yet code-up.

#785 (Set prognostic cloud-fractions in LAM LBCs when using the PC2 cloud-scheme) – Regional Model Evaluation and Development

#7927 (Set PC2 area cloud fraction consistently in LAM-domain edge points) – Unified Model



Prognostic cloud-fractions inherit previous junk from LAM domain edge halo points when winds blow into the domain.

#7948 (Consistently increment prognostic cloud when using horizontal turbulent mixing with PC2) – Unified Model



300m runs occasionally crash due to area-cloud-fraction (used by radiation) not set at LAM boundary points.

#7949 (Implement PC2 erosion when using PC2 with CASIM and no convection scheme) – Unified Model



PC2 cloud-fraction update from horizontal turbulent mixing has never been implemented => fields become inconsistent.



PC2 erosion not yet implemented with CASIM => partial cloud-fractions wrongly persist forever!